

There was a lot  
of crime in her  
neighborhood,  
and Marie . . . .

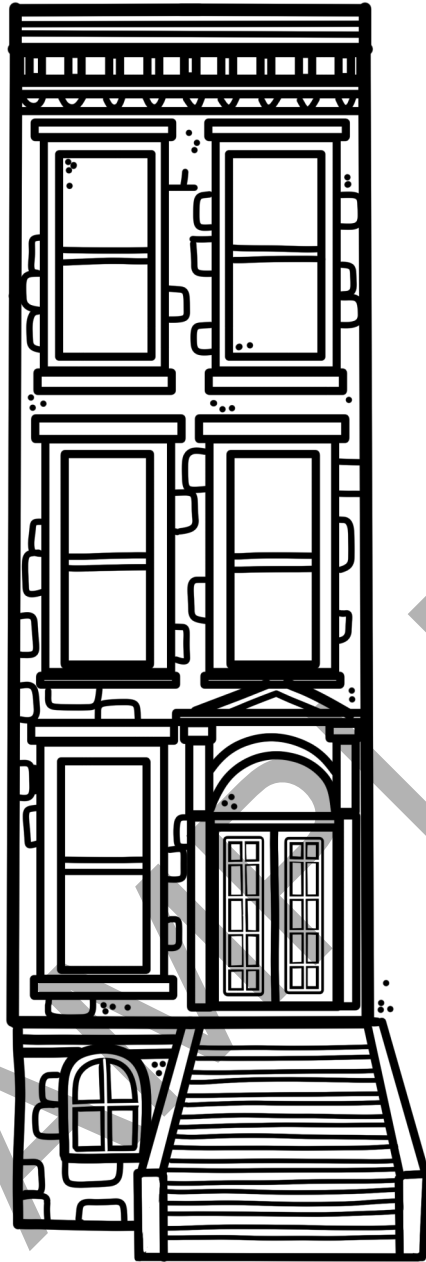

was often home  
alone because of  
the hours she and  
Albert worked.

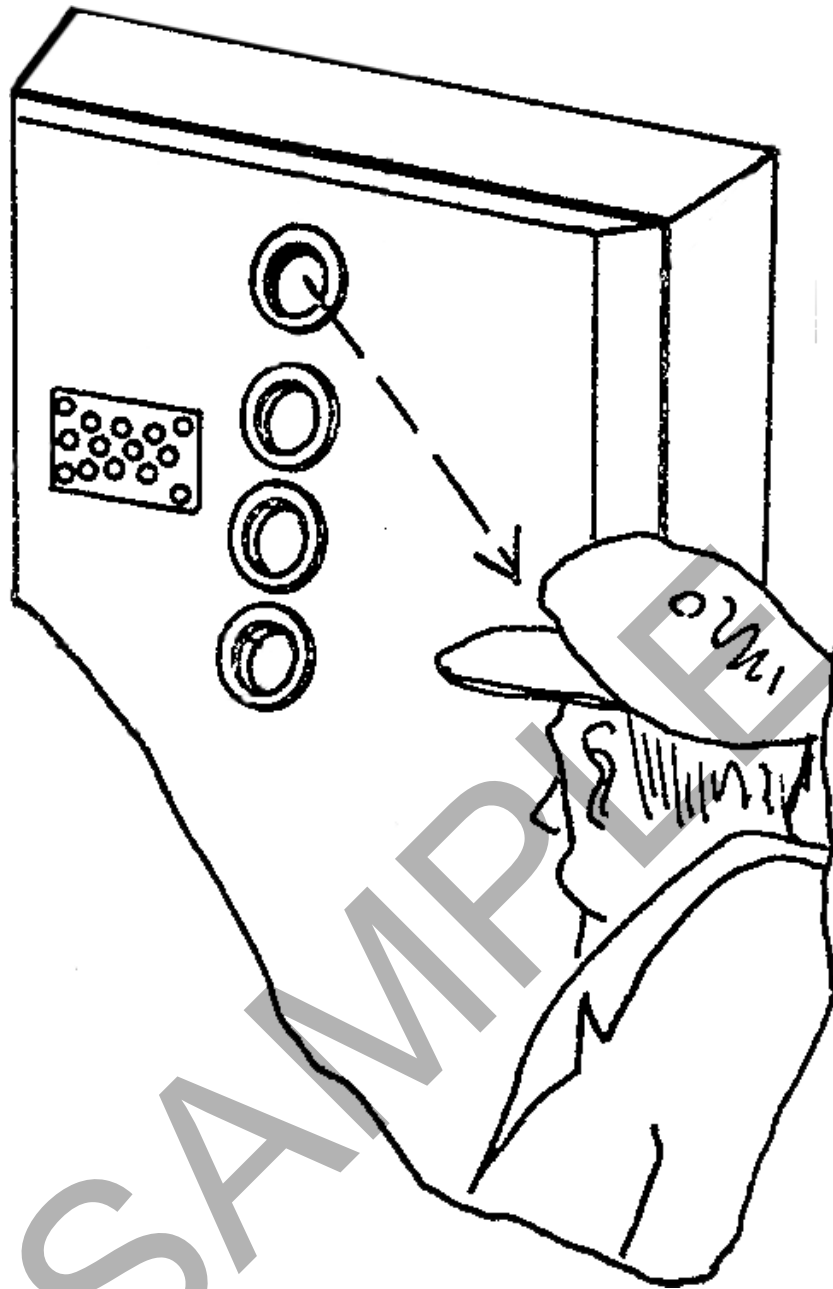

In 1966, she put  
together four  
peepholes, a sliding  
camera, . . .

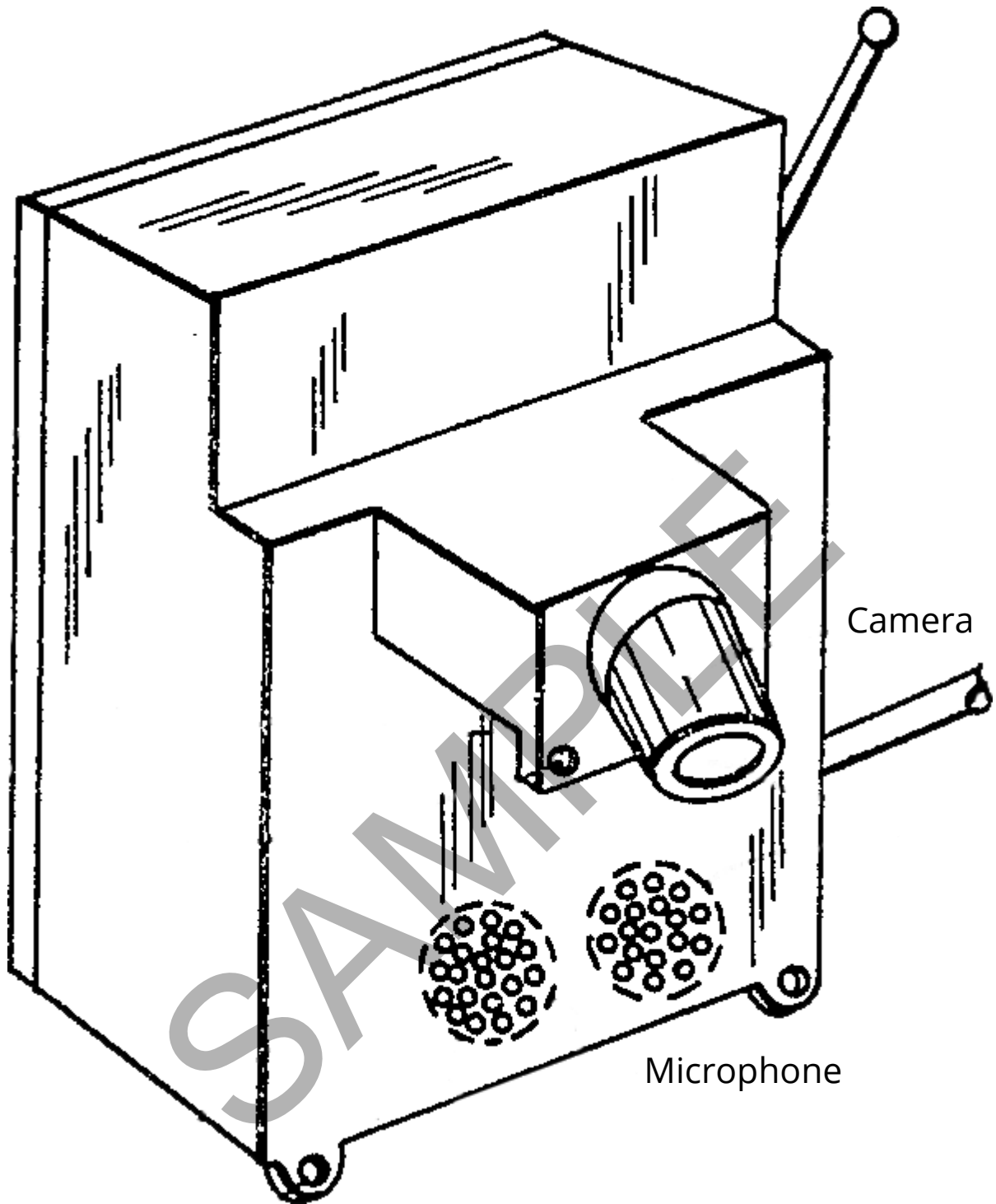

television monitors,  
and two-way  
microphones.

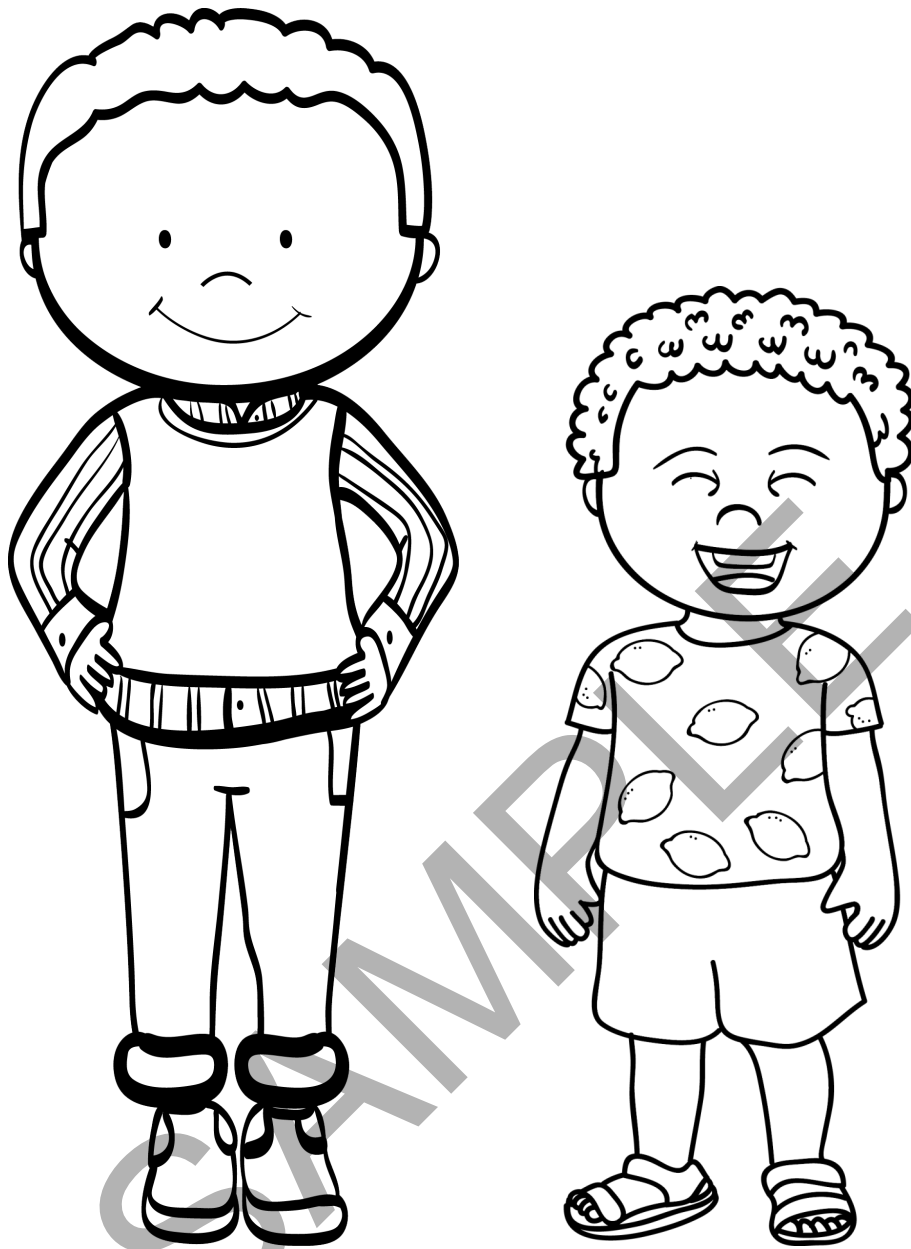

The camera slid up  
and down so she  
could see people of  
different heights.

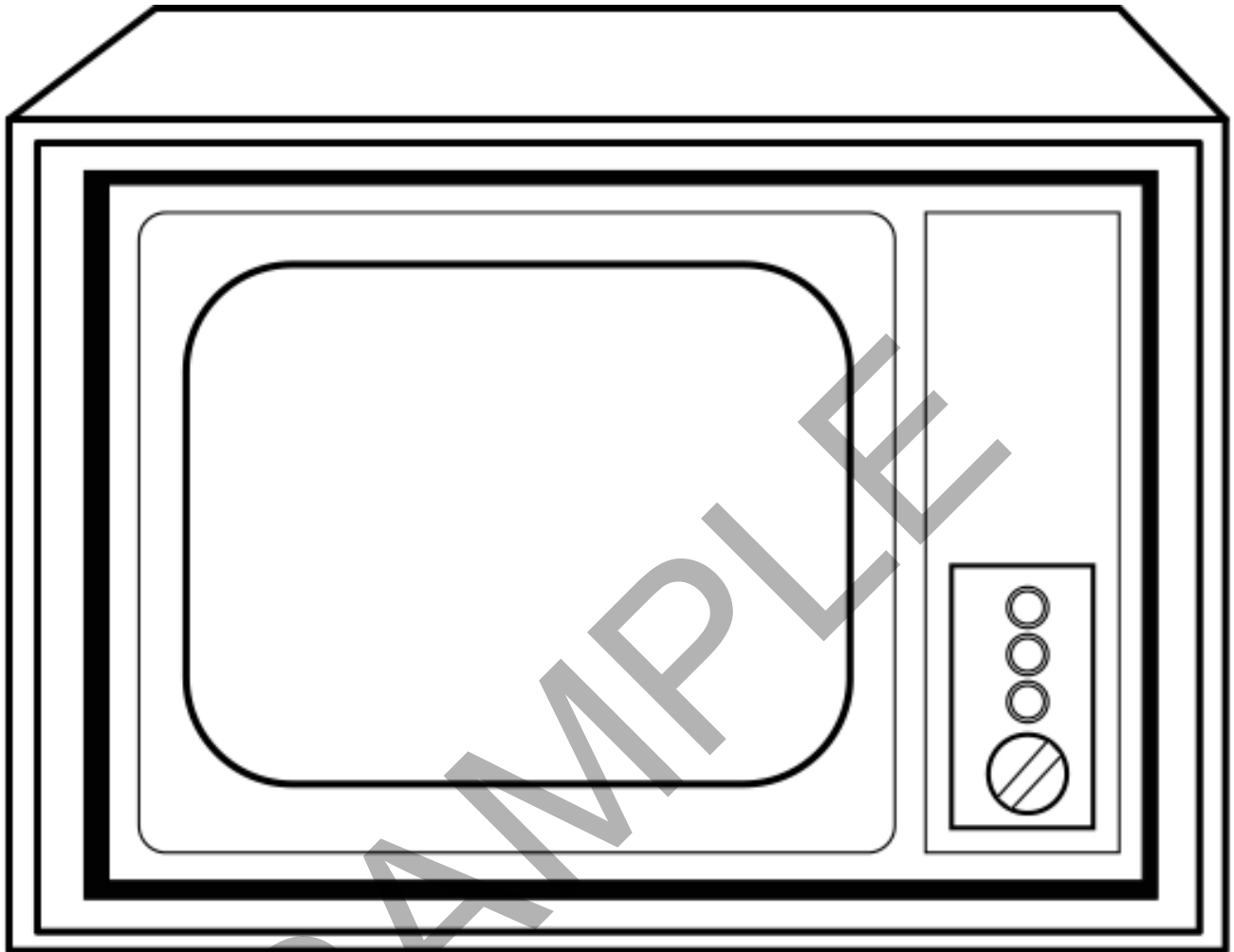

It relayed what it  
saw to a television  
screen inside.